

Golf Bag *assembly instructions*

sku #25383

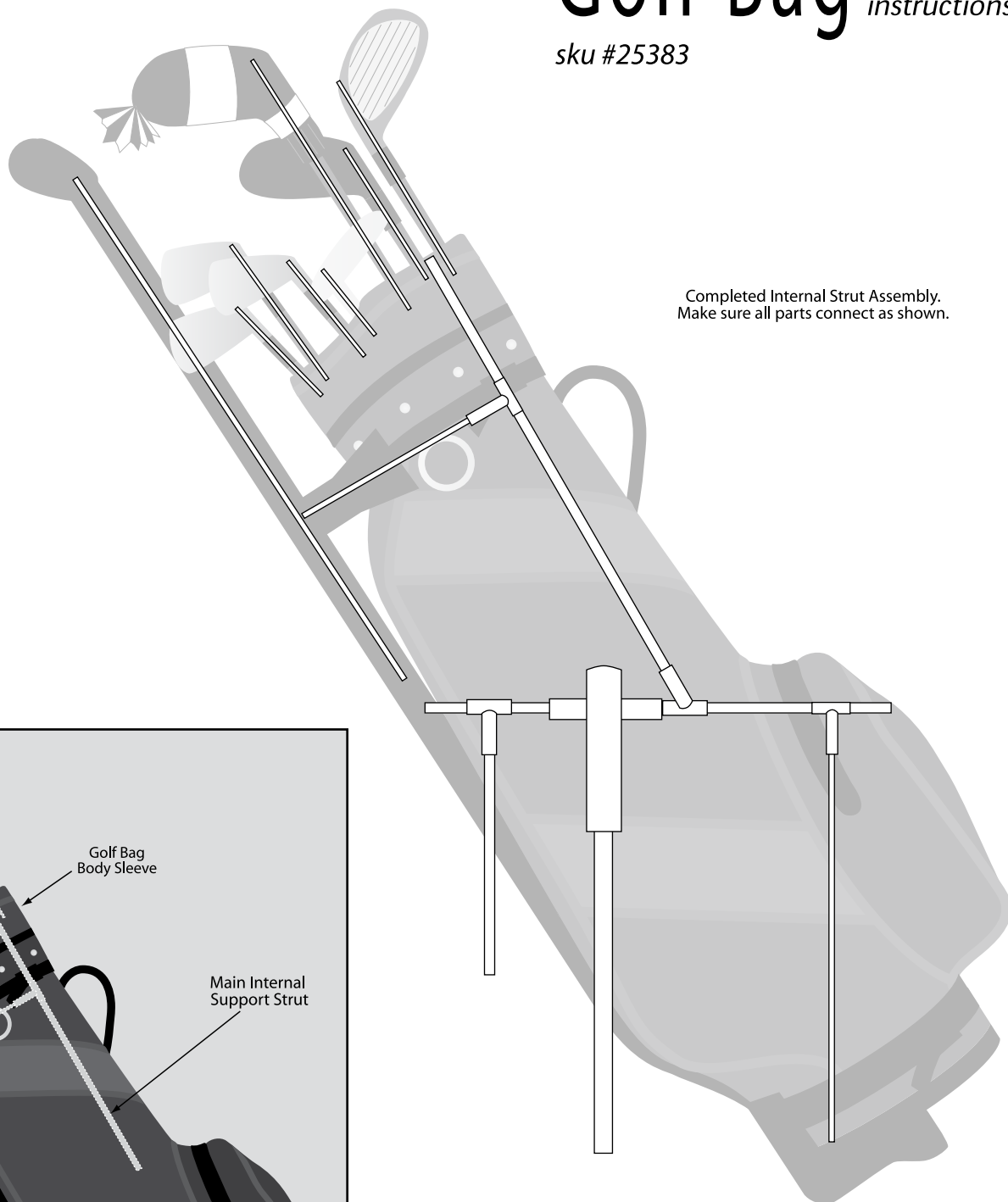

Completed Internal Strut Assembly.
Make sure all parts connect as shown.

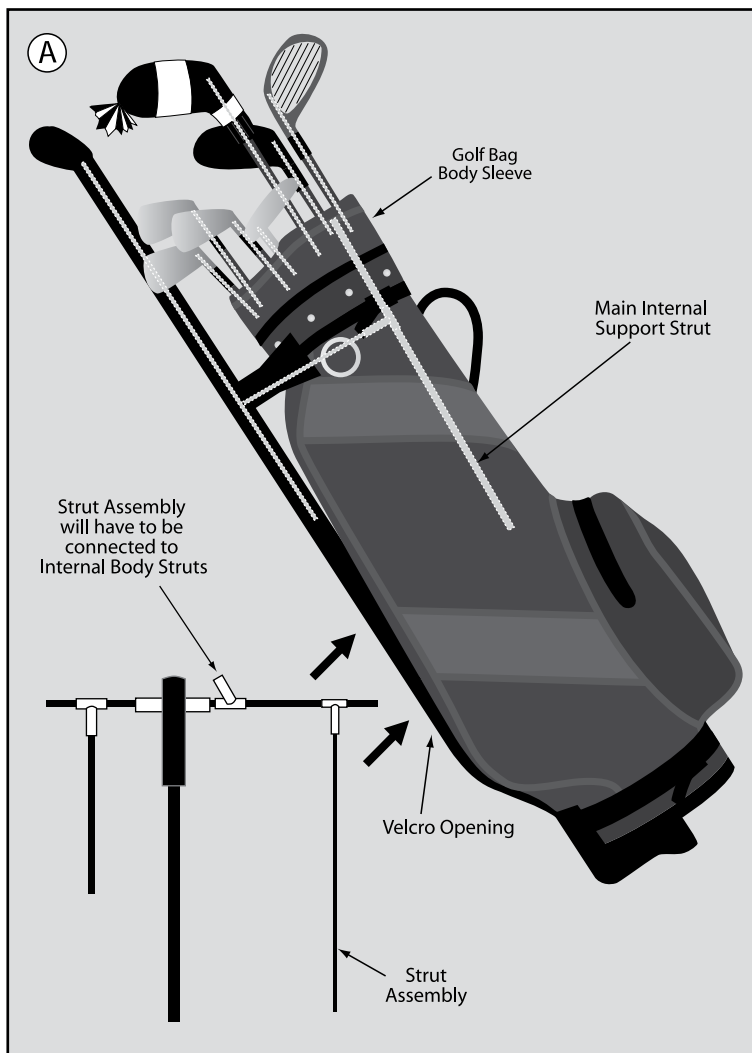

Step 1

The Strut Assembly of your Golf Bag spinner is shipped in two sections. Open the Velcro straps and insert Strut Assmebly into Golf Bag Body Sleeve. Connect Strut Assmebly to the Main Internal Support Strut as shown. Strut Assmebly will have to enter Body Sleeve at an angle in order to connect to the Main Internal Support Strut and then be positioned into place. Reclose Velcro straps. (diagram A)

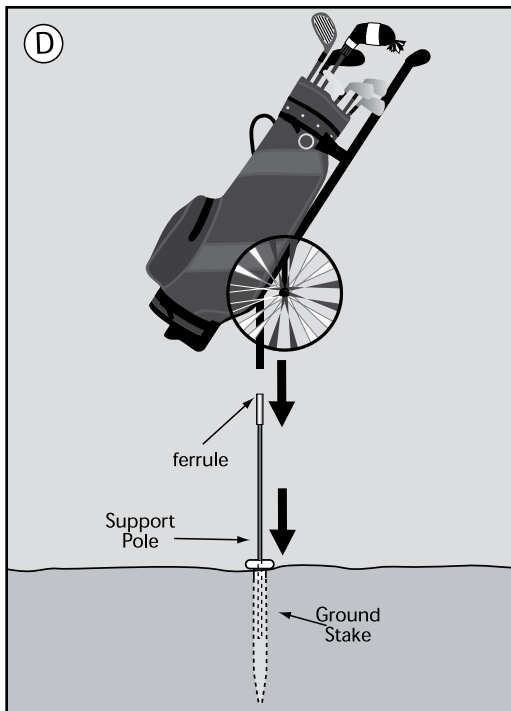
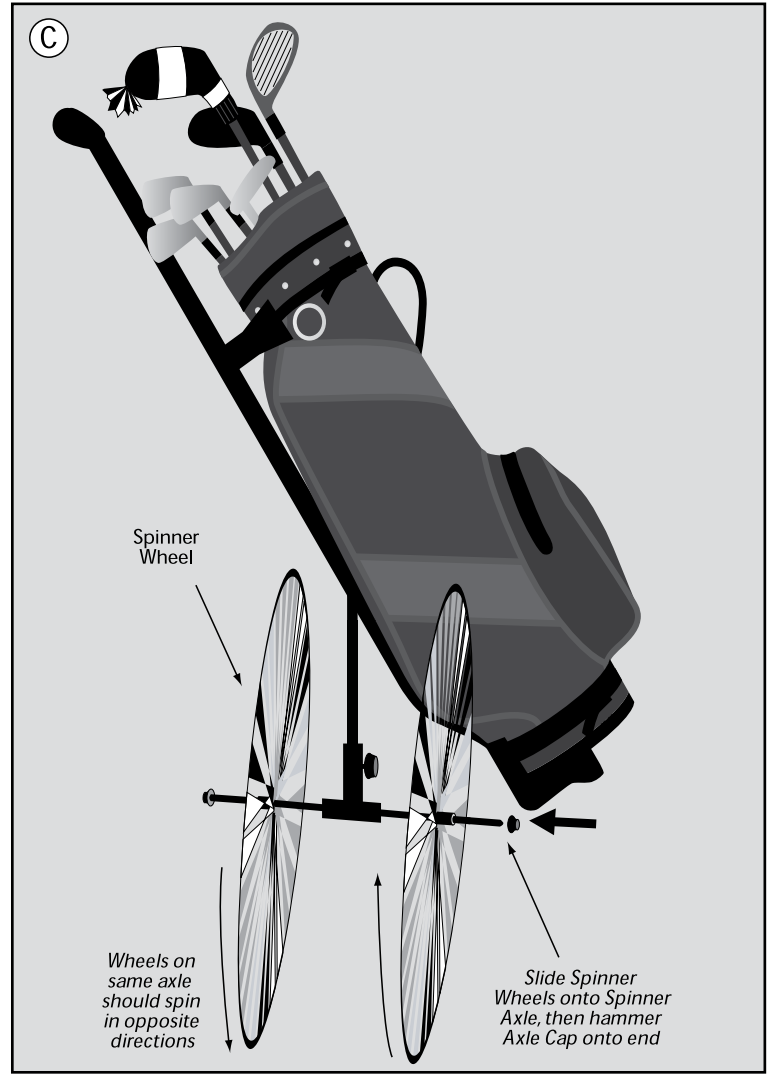
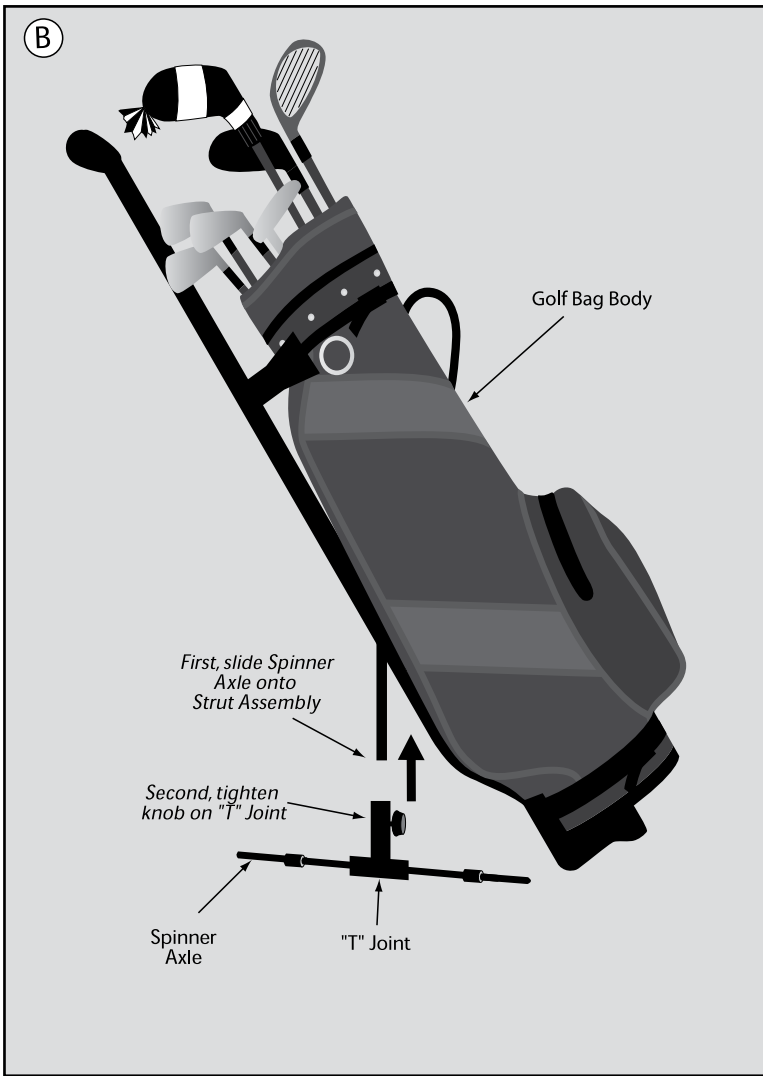

Step 2

Take one of the Spinner Axles and slide it onto the Strut Assembly of Golf Bag Body. Tighten knob on the "T" Joint to hold the Axles to the Struts. (diagram B)

Step 3

Take one of the two Spinner Wheels and slide it onto the Spinner Axle. Slide second Spinner Wheel onto Spinner Axle. **(Note: Spinner Wheels on same axle should spin in opposite directions.)** Pound Axle Caps onto uncapped end of Spinner Axle using a mallet or piece of wood. (diagram C)

Step 4

Pound Ground Stake into ground and insert non-ferruled end of Support Pole into Ground Stake. Insert Upper Pole Section of completed Golph Bag Spinner into ferrule on top of Support Pole. (diagram D)

PLEASE NOTE: Although your Golf Bag Spinner is constructed with UV resistant SunTex™ fabric, it is recommended that you take it inside during storms and harsh weather to preserve its durability.