

Step 1

The Strut Assembly of your Bass Spinner is shipped in three sections. Open the velcro closure at the base of the tail. Connect Center Rod of Lower Strut Assembly to Center Rod of the preinserted Upper Strut Assembly by joining ends of Ferrule Connector as shown. Reclose the velcro closure. (diagram A)

Step 2

Open velcro tab and insert horizontal Support Rod into sleeve and connect into "T" joint as shown. Reclose velcro tab. The Upper horizontal Support comes already in place. If it comes loose, open the velcro tab and reinsert it into the "T" joint. (diagram B)

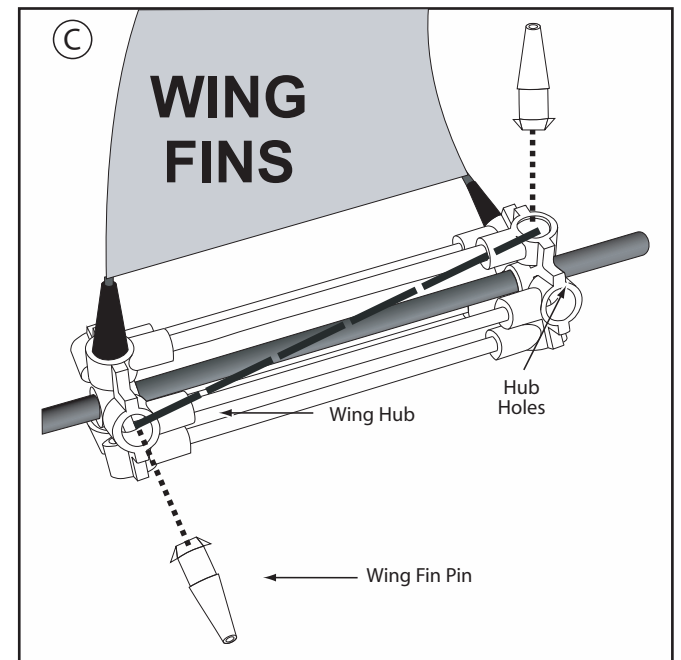

Step 3

Attach Wing Fins to Wing Hub. **Please note that Wing Fins are inserted at an offset pattern.** Make sure Wing Fins are fully inserted into hub holes. You will hear a "click" sound when the pins are all the way in. (diagram C)

PLEASE NOTE: If you make a mistake in the placement of the Wing Fins (i.e. backward, wrong color sequence etc.), you can remove them by carefully inserting a small flat end screwdriver between the base of the Wing Fin Pin and the hub and pushing it up and out.

Step 4

Drive Ground Stake into ground. Slide Ground Shaft into Ground Stake. Slide Main Hub Assembly with Garden Spinner over Ground Shaft Ferrule. (diagram D)

PLEASE NOTE: Although your Garden Spinner is constructed with UV resistant SolarMax™ fabric, to preserve its durability, we recommend taking spinner inside during harsh weather or when not in use.

