

Plane Fuselage x 1

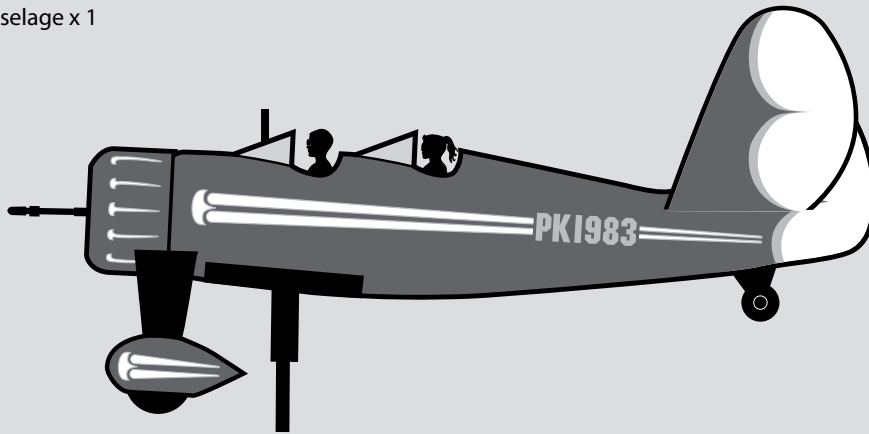

Spinner Propeller x 1

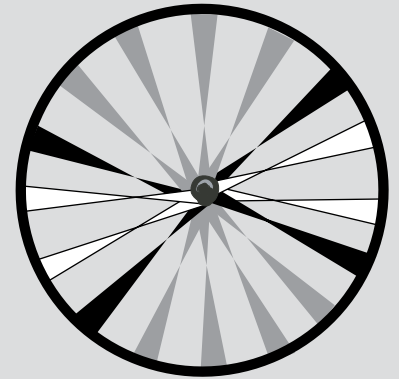

Wing x 3

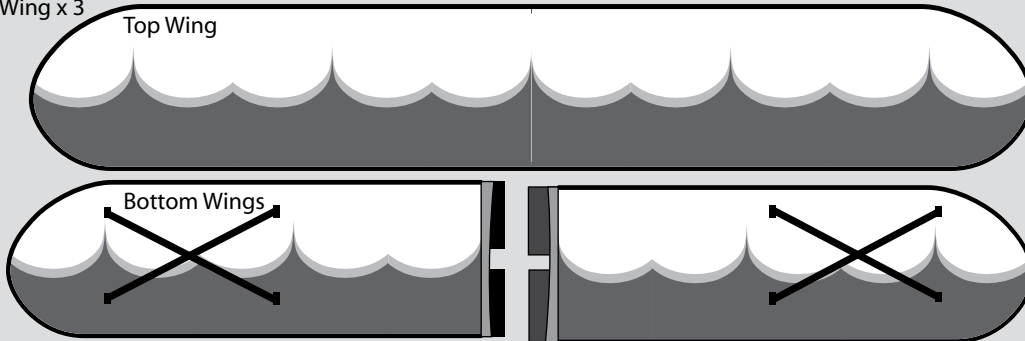

Landing Gear Struts x 2

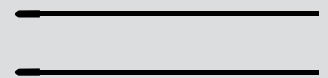

Landing Gear Wheel Axle x 1

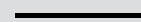

Stabilizer Cross Strut x 1



Support Pole x 1

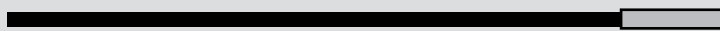

Ground Stake x 1

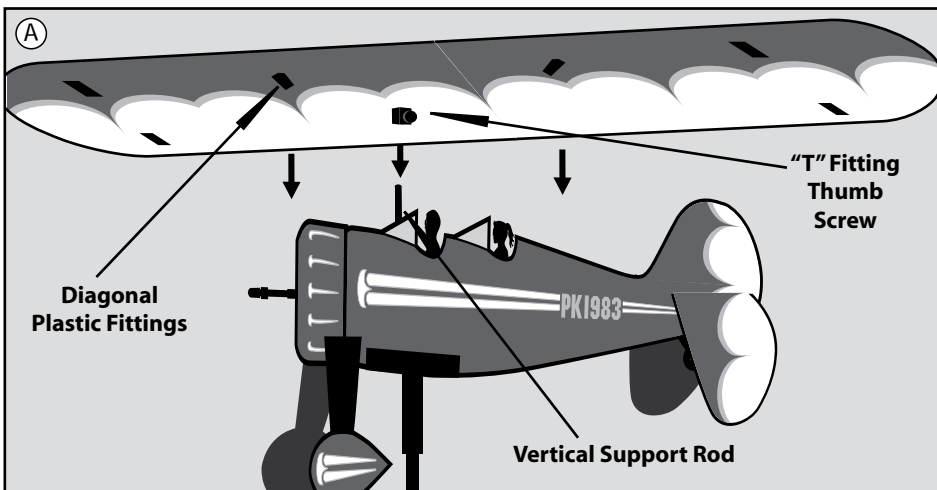

Step 1

Slide the top wing's "T" Fitting Thumb Screw onto the Internal Vertical Support Rod. Be sure to tighten the top wing's "T" Fitting Thumb Screw to secure the wing to the fuselage. Make sure the wing is fully seated on the Vertical Support Rod. (diagram A)

Step 2

Insert the Aluminum Ferrule attached to the Internal Wing Strut of the bottom Right Wing through the square opening of the Main Fuselage Hub. Then insert the bottom Left Wing's Internal Wing Strut into the Aluminum Ferrule, which is inside the channel of the Main Fuselage Hub. (diagram B)

Step 3

Secure the bottom wings to the fuselage with the Velcro tabs on both the top and bottom of the Left and Right Wings. (diagram C)

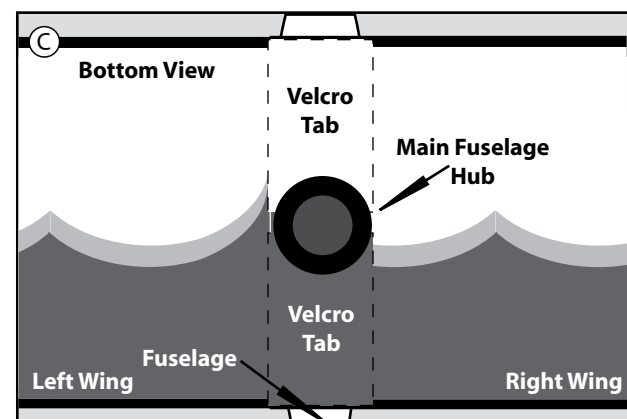
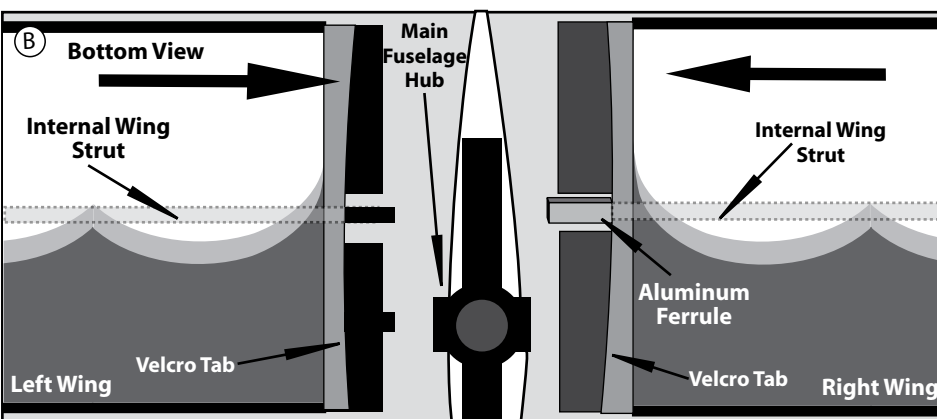

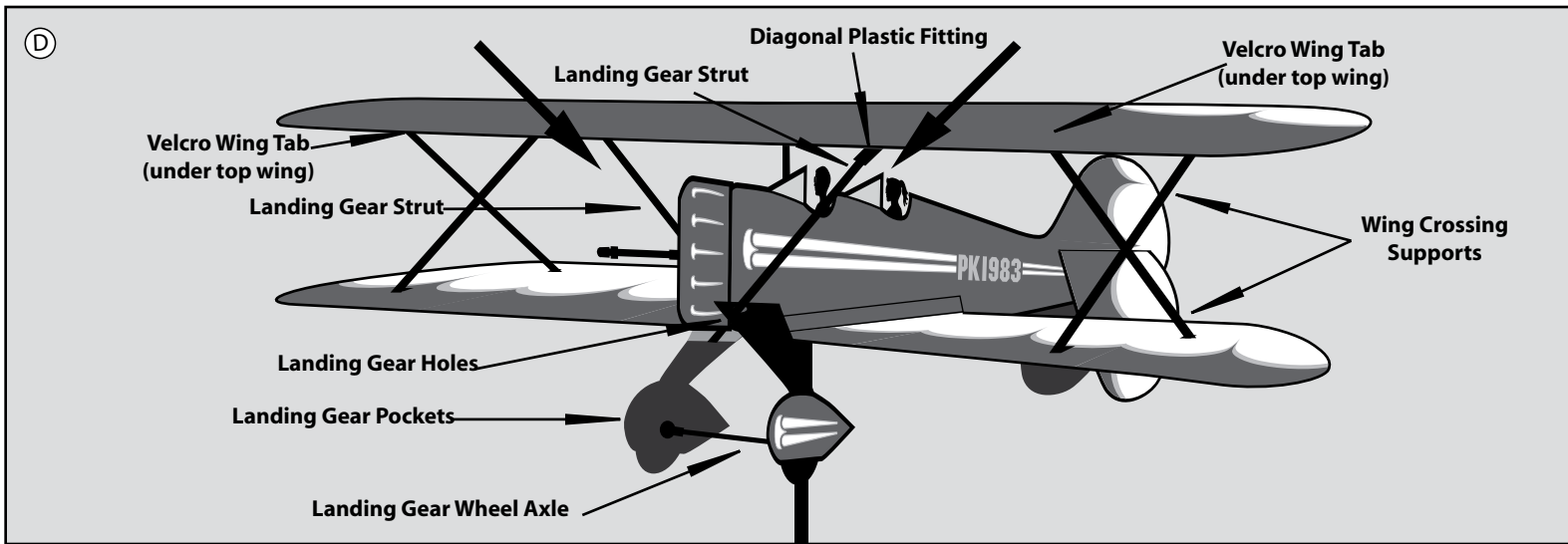

Step 4

Insert both Landing Gear Struts through the Landing Gear Holes into the Landing Gear Pockets, located at the front of the plane. These struts should cross each other and form an "X". Then insert the Landing Gear Struts into the two black Diagonal Plastic Fittings on either side of the top wing. Then insert the Landing Gear Wheel Axle into the two black fittings located between the two landing gear pockets. Then secure the black, Wing Crossing Supports to the Velcro Wing Tabs located underneath the top wing. (diagram D)

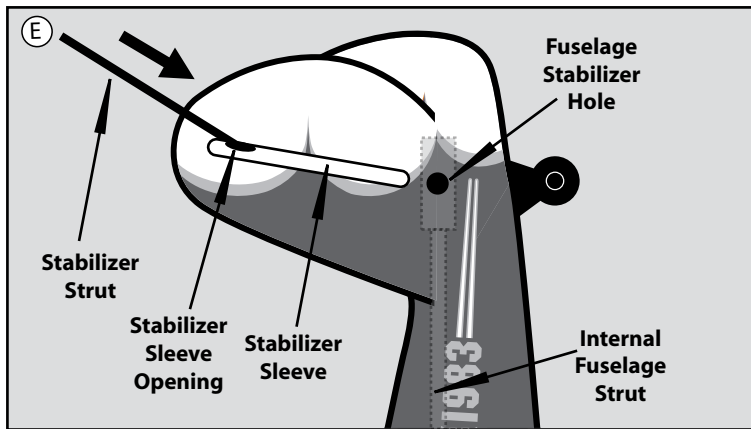

Step 5

Insert the Stabilizer Strut into the opening of the Stabilizer Sleeve located underneath the stabilizer. Guide the Stabilizer Strut through the Fuselage Stabilizer Hole and to the other side. Then slide the Stabilizer Strut through the other sleeve on the other side of the stabilizer. (diagram E)

You may have to shift the Fuselage Stabilizer Hole slightly to line up the stabilizer strut through the hole. Shifting the Fuselage Stabilizer Hole can be accomplished by grabbing the main fuselage hub and moving the internal fuselage strut.

Step 6

Remove the plastic end cap and spacer from the propeller axle exiting from the front end of the fuselage. Slide on the Spinner Propeller. Place the Spinner Propeller onto the propeller axle, then replace the spacer and the end cap. (diagram F)

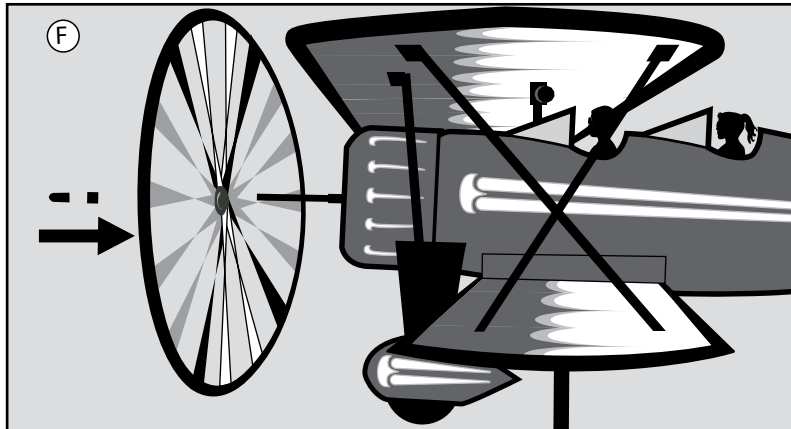

Step 7

Pound Ground Stake into ground and insert non-ferruled end of Support Pole into Ground Stake. Insert Upper Pole Section of completed Biplane Spinner into ferrule on top of Support Pole. (diagram G)

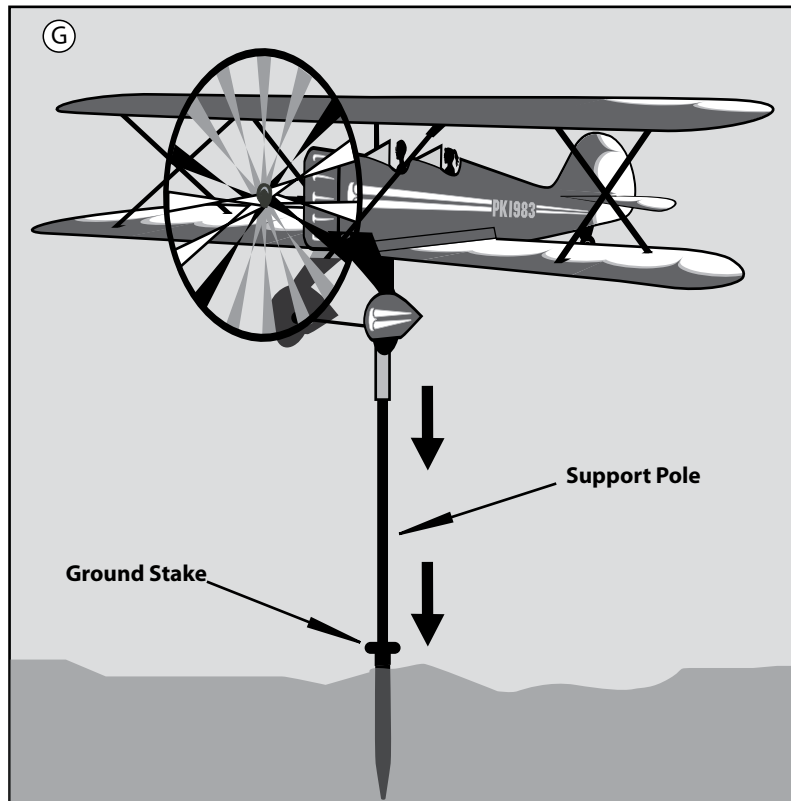

PLEASE NOTE: Although your Airplane Spinner is constructed with UV resistant SunTex™ fabric, it is recommended that you take it inside during storms and harsh weather to preserve its durability.