

Piper Cherokee Spinner assembly instructions

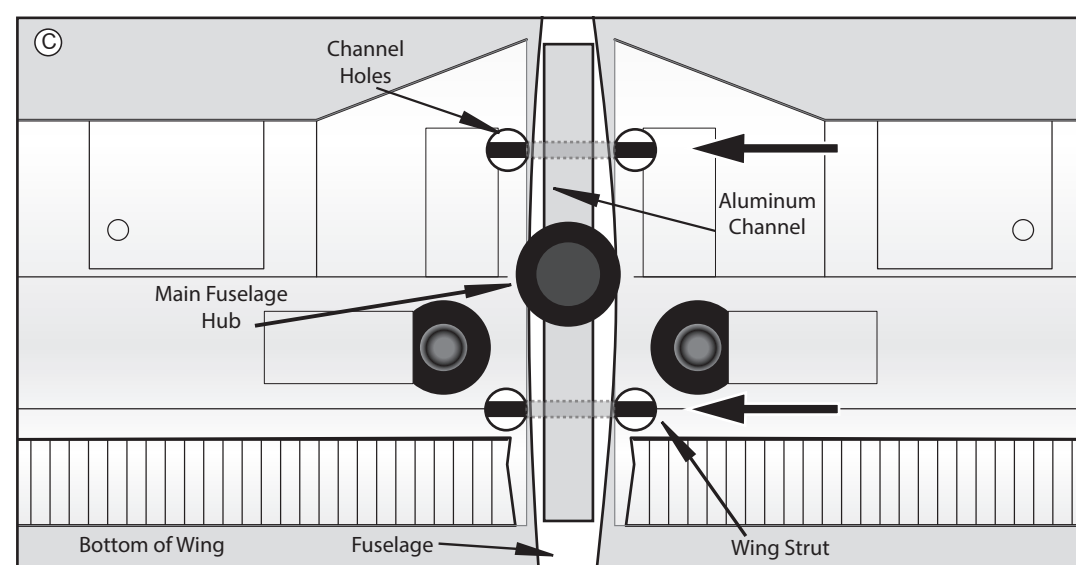
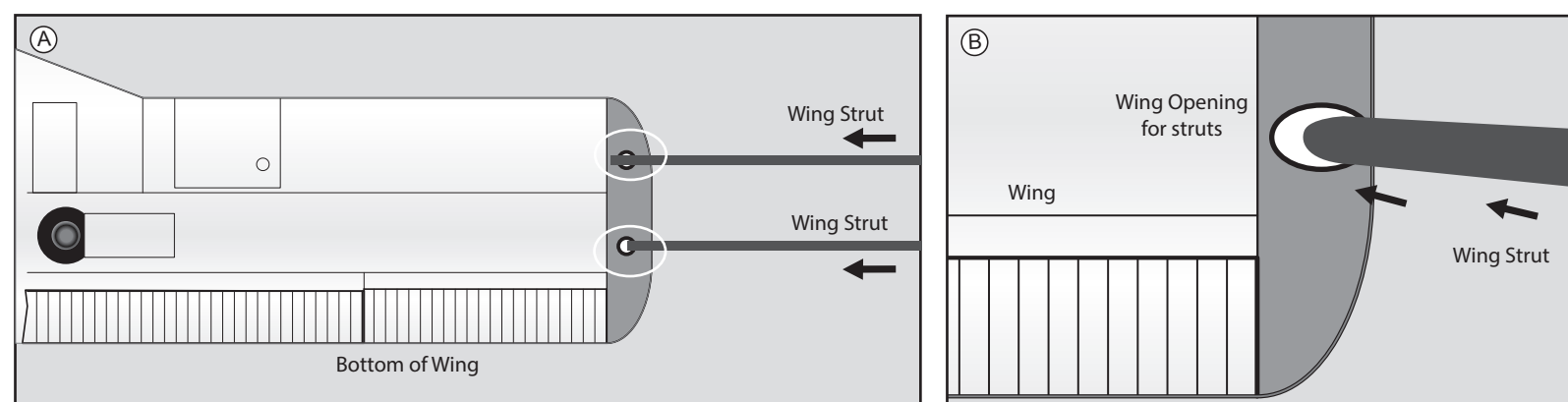
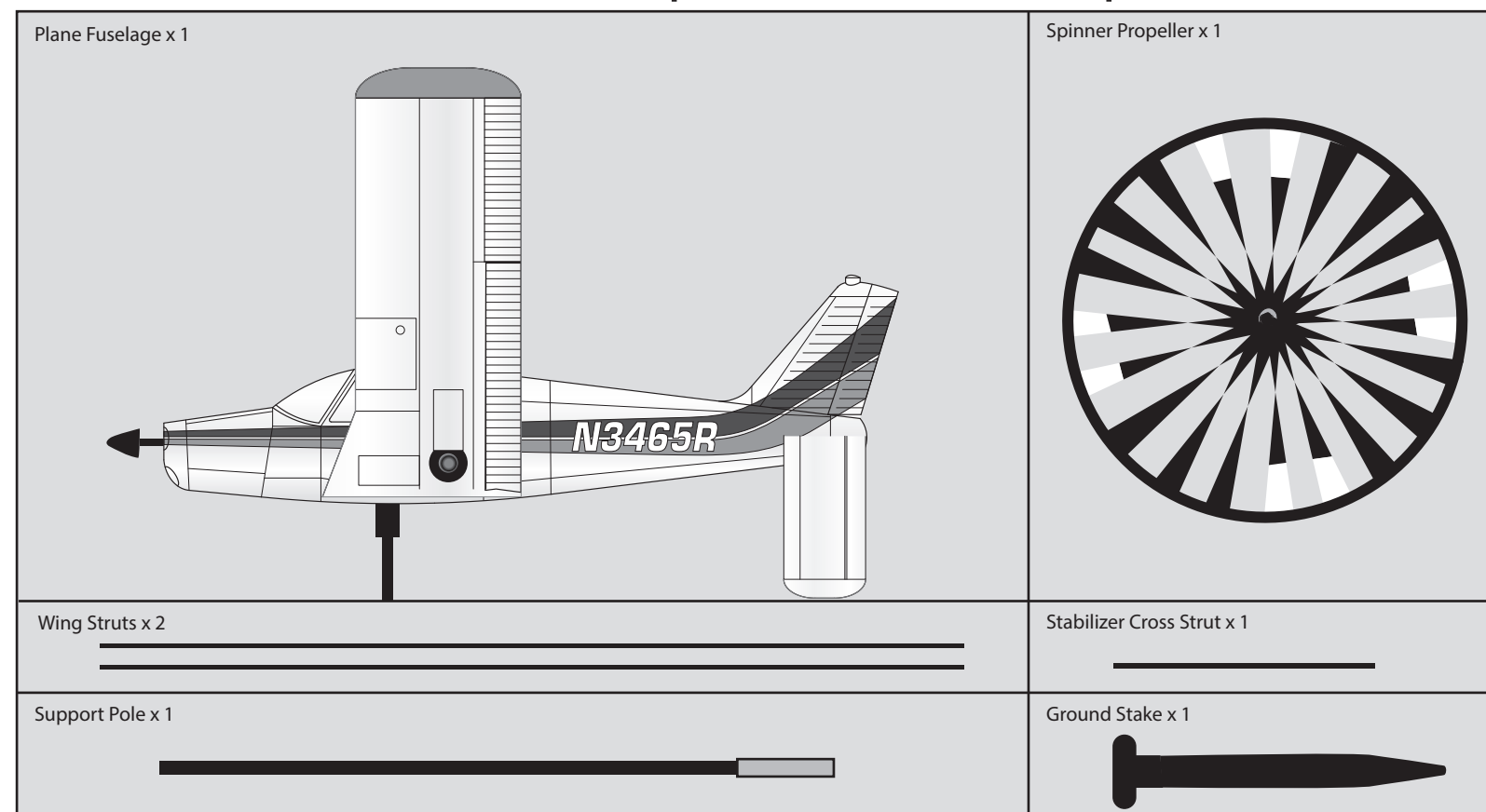

Step 1
Insert the two Wing Struts through the two openings at the wing tip of one of the wings. Guide them through the inside of the wings. (diagrams A & B)

Step 2
Pass the struts through the Channel Holes in the fuselage, found underneath the wings and through the Aluminum Channel inside the fuselage. Guide the struts through the inside of the wing to the other wing to the end of the wing tip. This wing tip should be sewn closed, so the struts can not pass through. You may have to shift the Fuselage Channels Holes slightly to guide them through. (diagram C)

FRONT

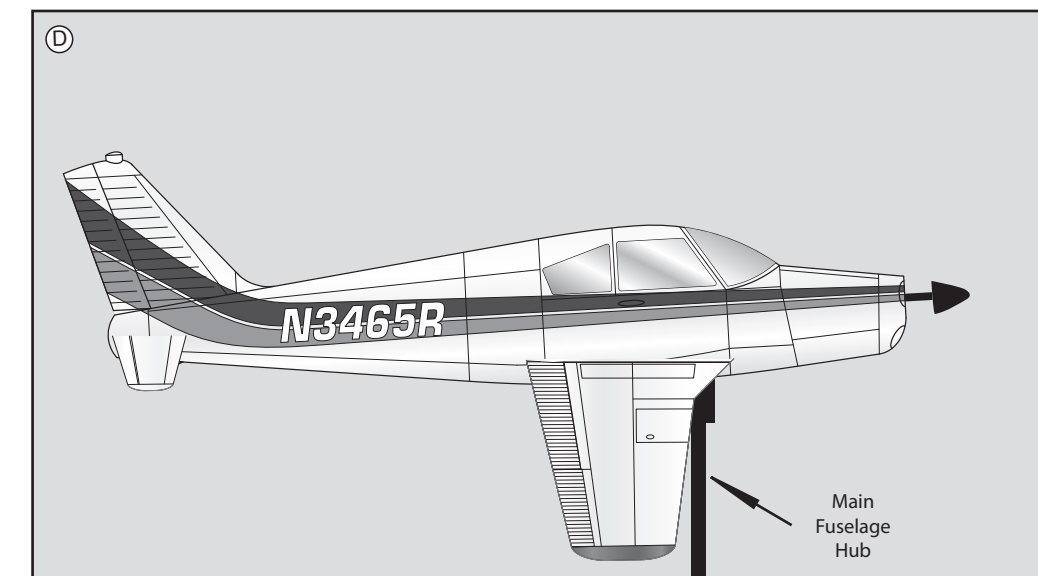

Step 3
Insert the Stabilizer Strut into the Stabilizer Sleeves located underneath the stabilizer. Guide the Stabilizer Strut through the Fuselage Stabilizer Hole and to the other side. Then slide the Stabilizer Strut through the other sleeve on the other side of the stabilizer. (diagram E)

You may have to shift the Fuselage Stabilizer Hole slightly to line up the stabilizer strut through the hole. Shifting the Fuselage Stabilizer Hole can be accomplished by grabbing the main fuselage hub and moving the internal fuselage strut.

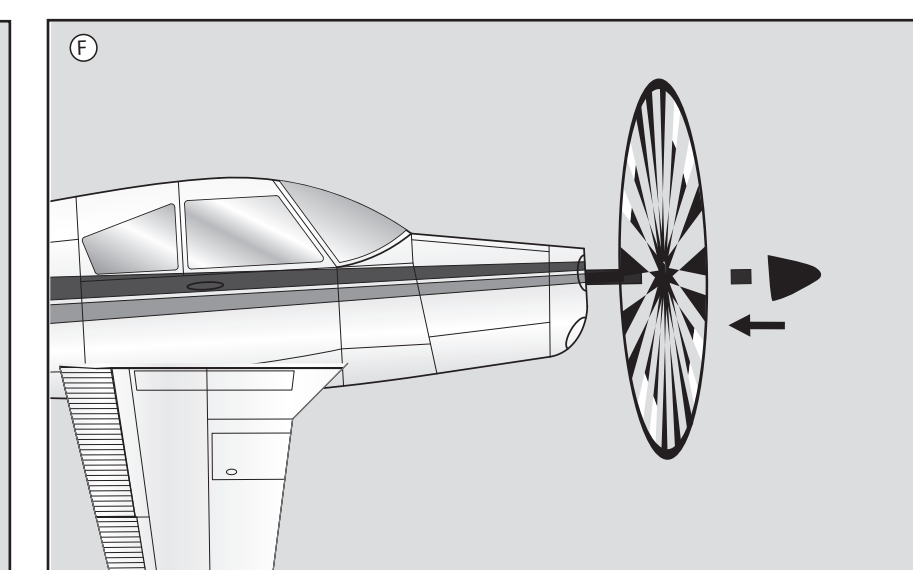
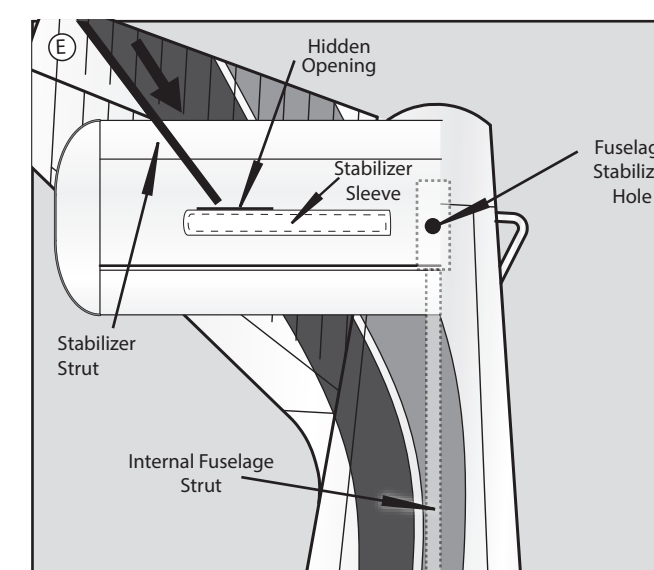

Step 4
Remove the white, wooden end cap and spacer from the propeller axle exiting from the front end of the fuselage. Slide on the Spinner Propeller. Place the Spinner Propeller onto the propeller axle, then replace the spacer and the end cap. (diagram F)

Step 5
Pound Ground Stake into ground and insert non-ferruled end of Support Pole into Ground Stake. Insert Upper Pole Section of completed Hellcat Spinner into ferrule on top of Support Pole. (diagram G)

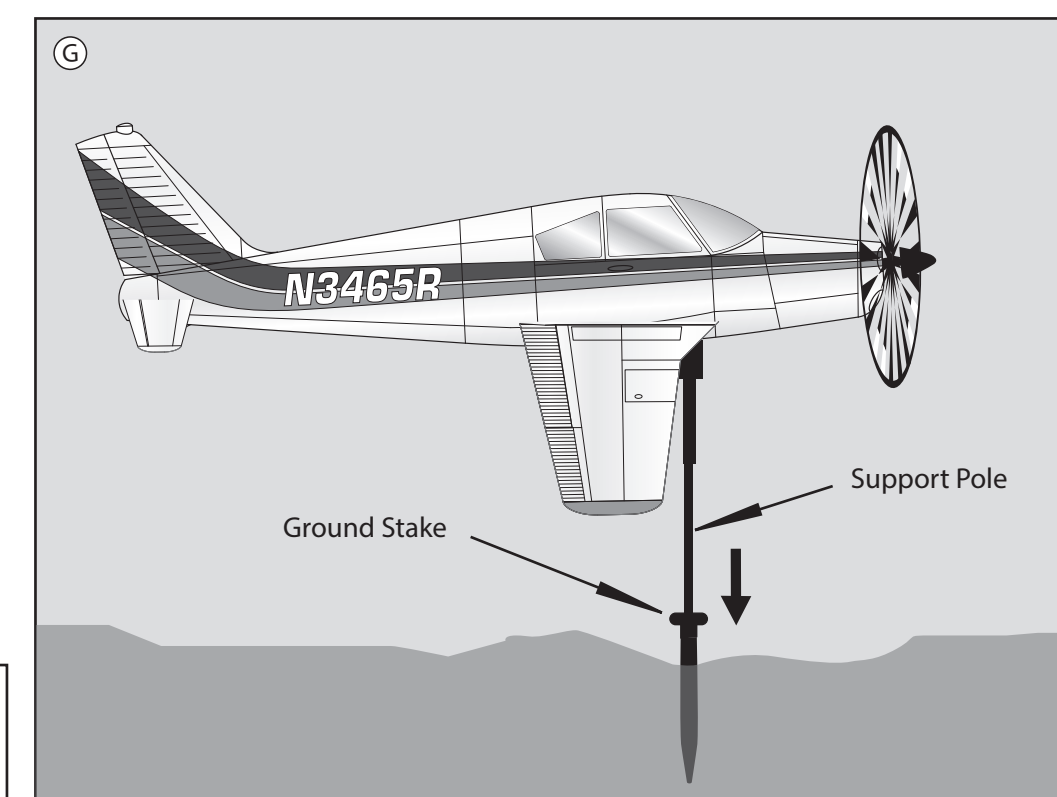

PLEASE NOTE: Although your Airplane Spinner is constructed with UV resistant SunTex™ fabric, it is recommended that you take it inside during storms and harsh weather to preserve its durability.

BACK